

FILTERS | AUTOMATIC SELF CLEANING SCREEN FILTERS |
HYDRAULIC ODISMATIC FILTERS

ODISMATIC 852R



Inlet Outlet Diameter	Filtering Grade
300 mm / 12"	30 micron
350 mm / 14"	50 micron
400 mm / 16"	80 micron
450 mm / 18"	100 micron
500 mm / 20"	120 micron
	150 micron
	200 micron
	300 micron
	400 micron

SPARES:

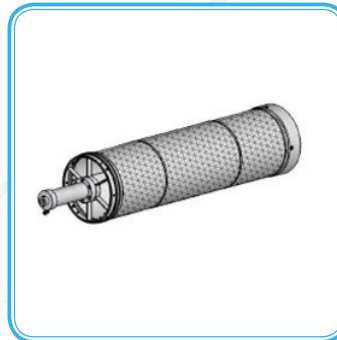
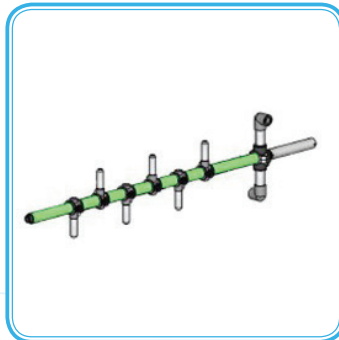

Name Series
Application

OdisMatic 852R
Automatic Self Cleaning Screen Filter in places without electricity. Filter is designed specially for high flow rates and liquid containing heavy dirt load due to the large screen area. Industrial waste water. Cooling towers process water. Process water. Water recycling. Municipal sewage. Pre filtration. For various industrial liquids, Sea water and Drinking water. Protection of hydraulic equipments like pumps valves and spraying nozzles.

Inlet Outlet Diameter
Max Flow Rate
Max Pressure
Min Working Pressure
Filtering Grade
Operation
Control

300 mm / 12" up to 500 mm / 20"
1600 m³/h / 7050 gpm
10 bar (150 psi)
2 bar (30 psi)
30 micron up to 400 microns
Automatic
Hydraulic, Manual